

OIL SKIMMER  
Type TJS25-115E, 165E, 200E, 250E, 300E

OIL SEPARATOR TANK  
ST-140(Option)

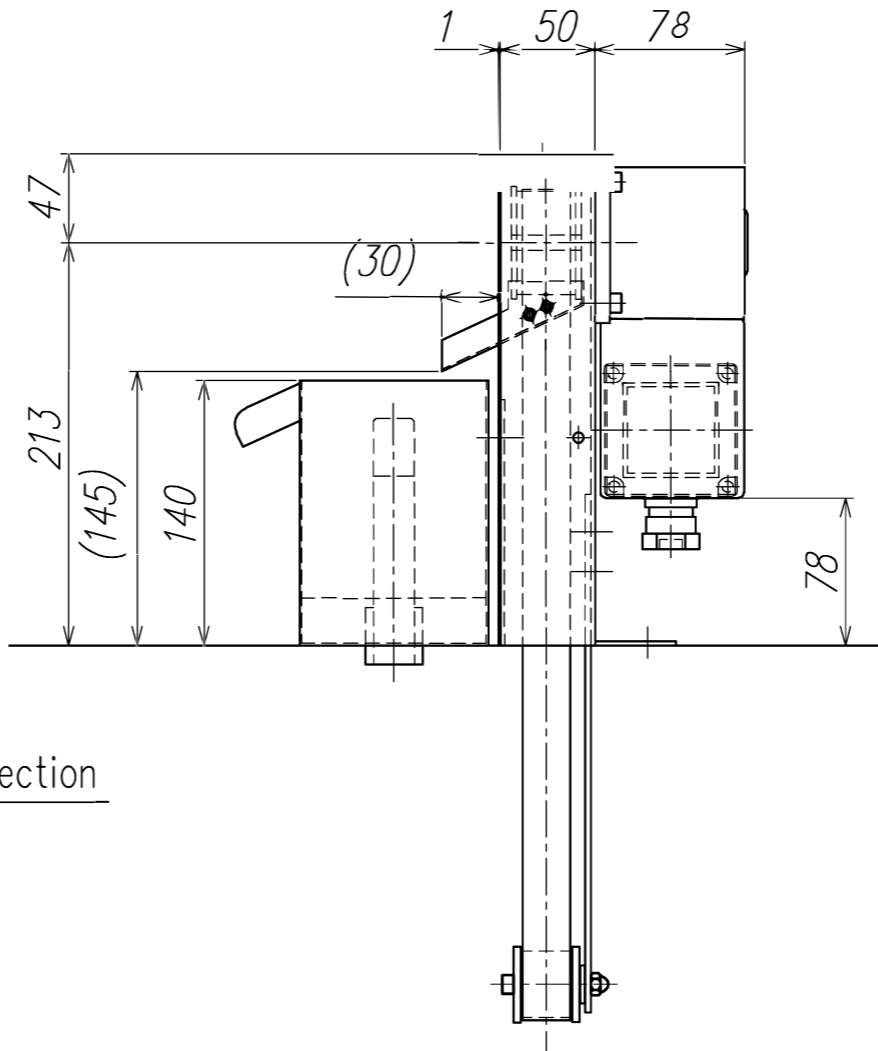
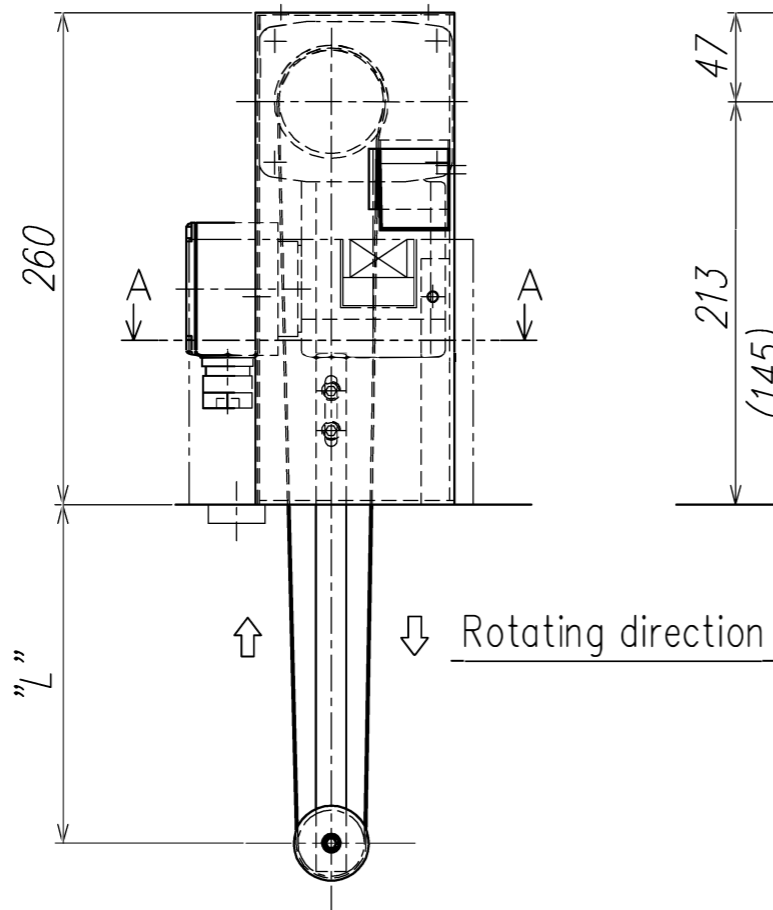
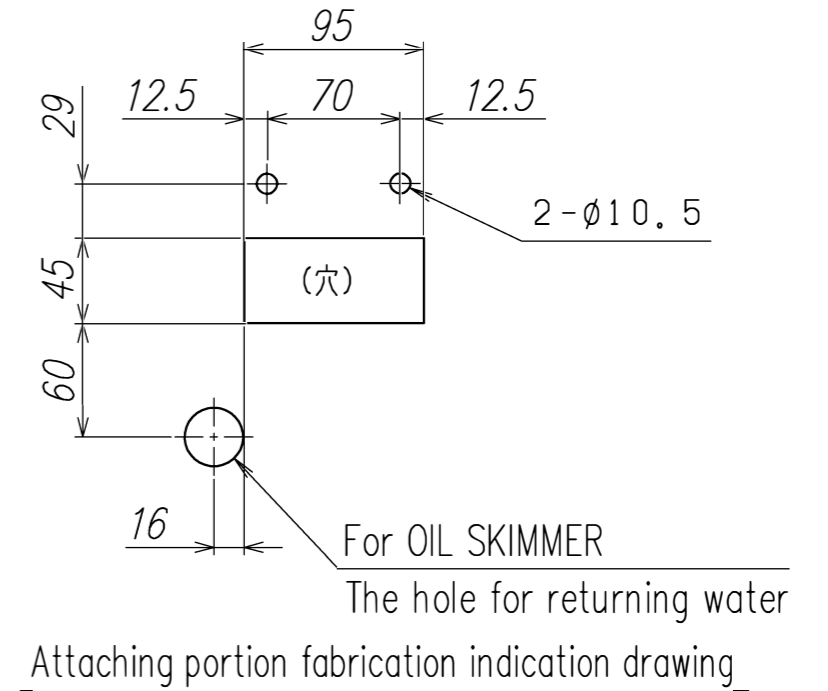
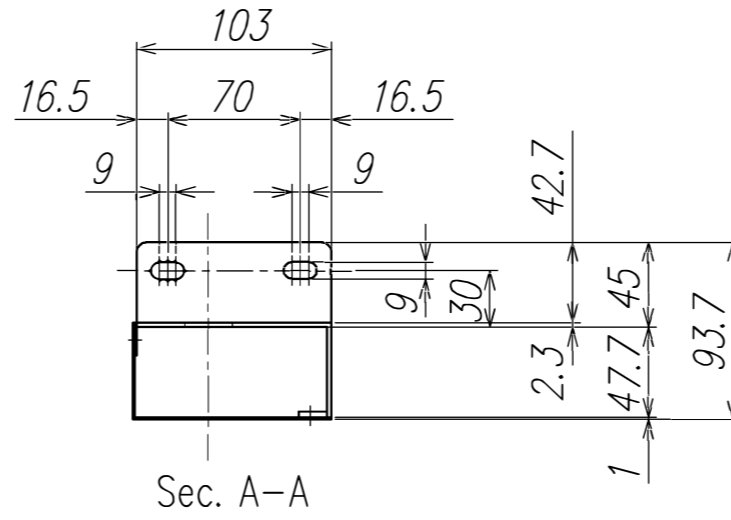
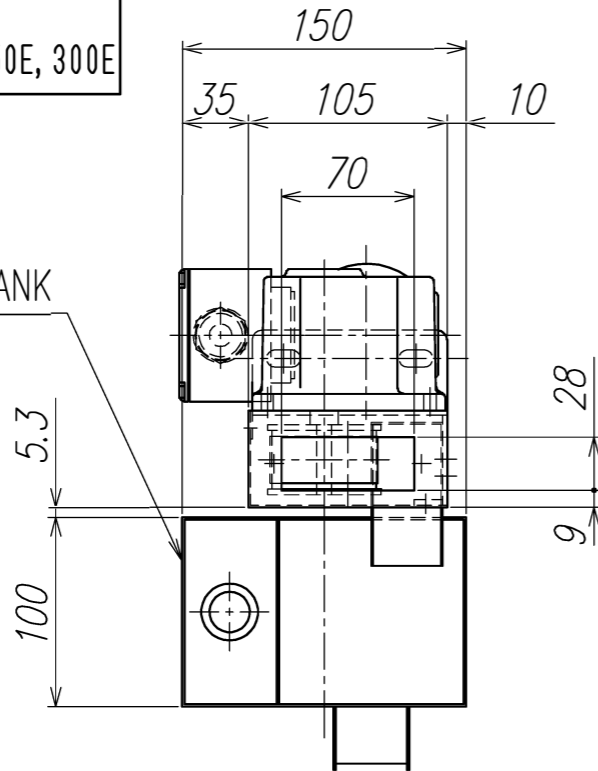

Motor Specification  
1. 200V/220V, 50/60Hz, 15w, 4P, 1/50  
2. Aluminum terminal box

| Dimension "L" | Type       |
|---------------|------------|
| 115           | TJS25-115E |
| 165           | TJS25-165E |
| 200           | TJS25-200E |
| 250           | TJS25-250E |
| 300           | TJS25-300E |

Note

2016.10.01

|                            |         |          |       |                                    |
|----------------------------|---------|----------|-------|------------------------------------|
| APPROVED                   | CHECKED | DESIGNED | SCALE | NAME                               |
|                            |         |          | 1/4   | OIL SKIMMER                        |
|                            |         |          |       | TJS25-115E, 165E, 200E, 250E, 300E |
| TK Takachiho America, Inc. |         |          |       | TJS25-* * * E                      |

