

1390S Series

RoHS Compliant

- 2 Member
- Linear Motion

Specification

- Material / SUS304
- Slide space / 6.4mm, Height / 14.0mm
- Mounting hole / M2.6 burring tap
 $\phi 2.8$, $\phi 2.8 \times 3.2$
- Common in L / R

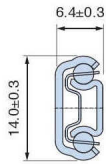
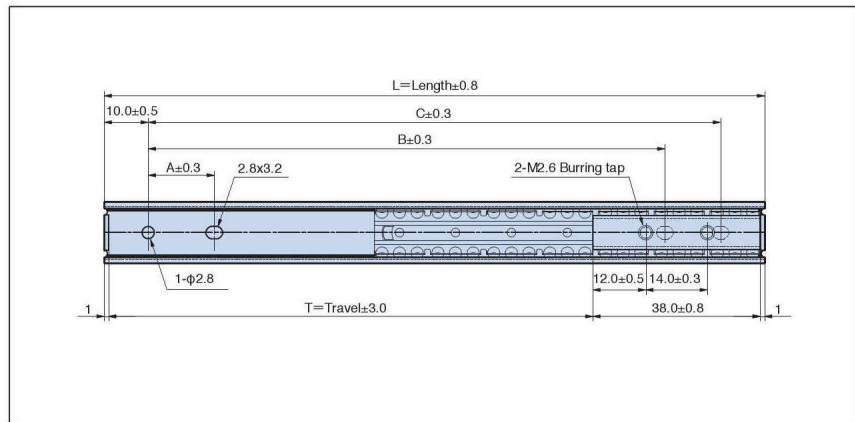

Cross sections

PART No.	Length L	Travel T	1390S Series Mounting Holes (mm)			Slide weight (kg/pc)
			A	B	C	
1390S-70	70	30	—	—	50	0.020
1390S-100	100	60	15	65	80	0.025
1390S-125	125	85	15	90	105	0.030
1390S-150	150	110	15	115	130	0.035

1590S Series

RoHS Compliant

- 2 Member
- Linear Motion

Specification

- Material / SUS304
- Slide space / 7.5mm, Height / 16.0mm
- Mounting hole / M3 burring tap,
 $\phi 3.2$, $\phi 3.2 \times 3.8$
- Common in L / R

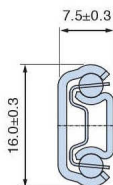
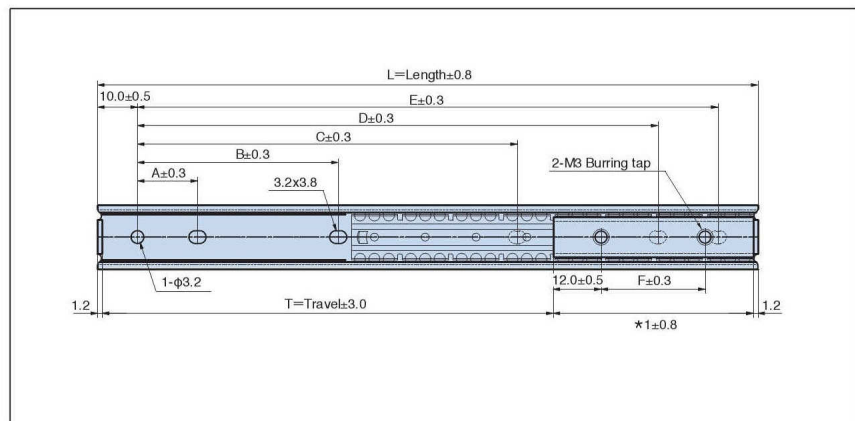

Cross sections

PART No.	Length L	Travel T	1590S Series Mounting Holes (mm)							Slide weight (kg/pc)
			*1	A	B	C	D	E	F	
1590S-70	70	29.6	38	—	—	—	—	50	14	0.025
1590S-100	100	59.6	38	15	—	—	65	80	14	0.030
1590S-125	125	84.6	38	15	—	—	90	105	14	0.040
1590S-150	150	109.6	38	15	—	—	115	130	14	0.045
1590S-200	200	147.6	50	15	—	—	165	180	26	0.060
1590S-300	300	247.6	50	15	90	190	265	280	26	0.080
1590S-400	400	347.6	50	15	130	250	365	380	26	0.105

1790 Series

RoHS Compliant

- 2 Member
- Linear Motion

Specification

- Material / SPCC
- Finish / Electro zinc plate with clear
- Slide space / 8.0mm, Height / 20.0mm
- Mounting hole / $\phi 3.2$, 3.2x3.8
- Common in L / R

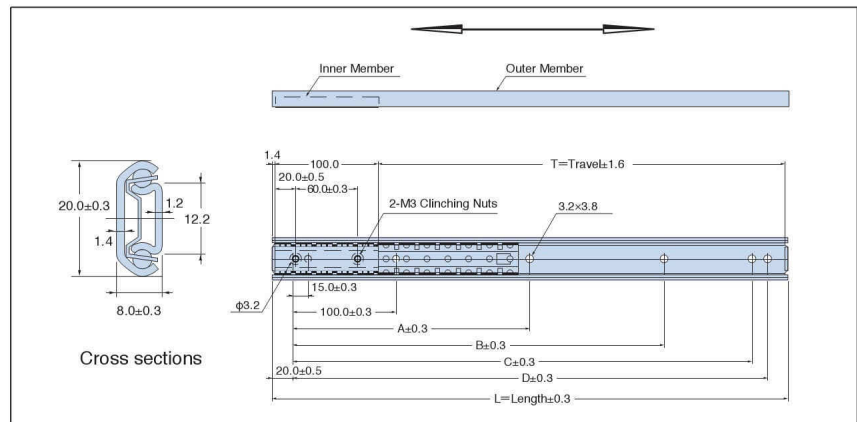

PART No.	Length L	Travel T	1790 Series Mounting holes (mm)							Slide weight (kg/pc)	Number in a box
			A	B	C	D					
1790-200	200	97	-	-	145	160	-	-	-	0.09	72
1790-250	250	147	-	-	195	210	-	-	-	0.11	72
1790-300	300	197	-	160	245	260	-	-	-	0.13	72
1790-350	350	247	-	210	295	310	-	-	-	0.15	72
1790-400	400	297	-	260	345	360	-	-	-	0.17	72
1790-450	450	347	205	310	395	410	-	-	-	0.19	72
1790-500	500	397	230	360	445	460	-	-	-	0.20	72

330LMM Series

RoHS Compliant

- 2 Member
- Linear Motion

Material / Stainless steel (Custom made)

Specification

- Material / SPCC
- Finish / Electro zinc plate with clear
- Slide space / 11.2mm, Height / 60.4mm
- Mounting hole / 4.5 5.2, 5.2 4.5
- Common in L / R

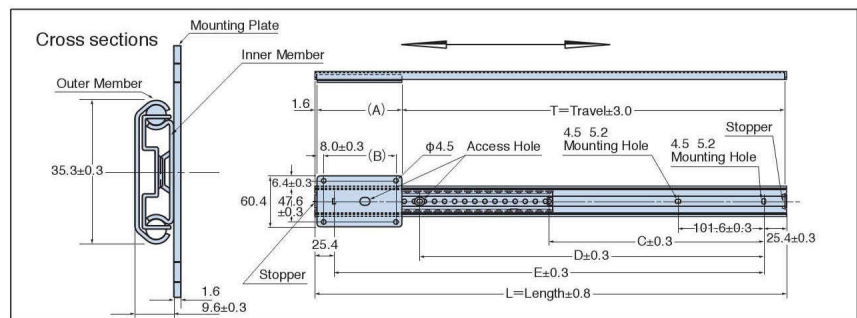

PART No.	Length L	330LMM Series Mounting holes (mm)									Slide weight (kg/pc)
		A						C	D	E	
		76.2	101.6	127.0	152.4	177.8	203.2				
		B									
60.2	85.6	111.0	136.4	161.8	187.2	Travel T					
330LMM-12	304.8 (12")	225.4	200.0	174.6	149.2	123.8	98.4	-	152.4	254.0	0.43
330LMM-14	355.6 (14")	276.2	250.8	225.4	200.0	174.6	149.2	-	203.2	304.8	0.46
330LMM-16	406.4 (16")	327.0	301.6	276.2	250.8	225.4	200.0	-	254.0	355.6	0.49
330LMM-18	457.2 (18")	377.8	352.4	327.0	301.6	276.2	250.8	203.2	304.8	406.4	0.52
330LMM-20	508.0 (20")	428.6	403.2	377.8	352.4	327.0	301.6	228.6	355.6	457.2	0.55
330LMM-22	558.8 (22")	479.4	454.0	428.6	403.2	377.8	352.4	254.0	406.4	508.0	0.58
330LMM-24	609.6 (24")	530.2	504.8	479.4	454.0	428.6	403.2	279.4	457.2	558.8	0.61
330LMM-26	660.4 (26")	581.0	555.6	530.2	504.8	479.4	454.0	304.8	508.0	609.6	0.64
330LMM-28	711.2 (28")	631.8	606.4	581.0	555.6	530.2	504.8	330.2	558.8	660.4	0.67

Roller Pack

RoHS Compliant

-R25- Aluminum Linear Motion Systems

Providing smooth & silent movement with wet area usage ability.

Storage Use : Slide rails for Furniture, Kitchen, etc.

Linear Motion Use : Medical Equipment, Gaming Machine, etc.

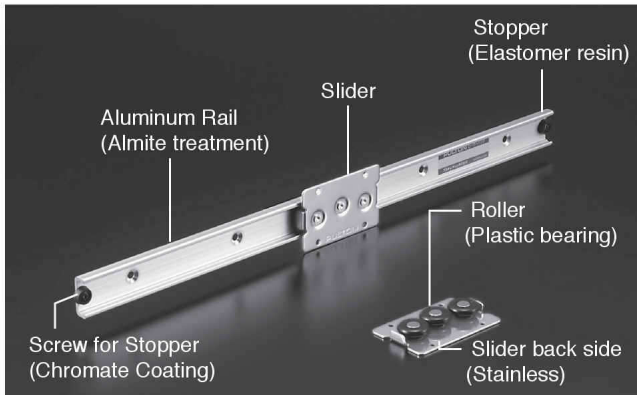

< Order >

2 - R25 - 160L

① ② ③

- ① Slider qty (No need to describe if only "1")
- ② Type of roller pack
- ③ Rail length

< Rail Dimension >

Part No.	Length L mm	Travel T mm	A mm	B	Weight (40g)
R25-160L	160	80	40	1	72
R25-240L	240	160	40	2	88
R25-320L	320	240	40	3	104
R25-400L	400	320	40	4	120
R25-480L	480	400	40	5	136
R25-560L	560	480	40	6	152
R25-640L	640	560	40	7	168
R25-720L	720	640	40	8	188
R25-800L	800	720	40	9	200
R25-880L	880	800	40	10	216
R25-960L	960	880	40	11	232
R25-1040L	1040	960	40	12	248
R25-1200L	1200	1120	40	14	280

Part Name	Material	Surface Finish
Rail	Aluminum Alloy	White Almite Treatment
Slider Plate	304SS	—
Roller	Polyacetar(POM)	—

* Weight is calculated in 1 slider.

* Weight of the slider plate individual is 40 g.

